



Car Front End Accessory Drive (FEAD) Basics Kit

77072445

5.7L & 6.4L Crate HEMI

www.mopar.com



Item	Description	Part Number	Quantity
	Car FEAD Basics Kit	77072445	
1	Idler Pulley Bolt, M8x1.25x34	06509487AA	2
2	Idler Pulley	04627851AA	1
3	Tensioner Bolt, M10X1.50X55.00	06104221AA	1
4	Belt Tensioner	04861660AA	1
5	Idler Pulley	04891720AA	1
6	Generator (Alternator), 180 AMP	04801833AB	1
7	Generator Bolt, M10X1.50X130.00	06506022AA	3
8	Generator Retaining Nut, M8x1.25	06502720	1
9	Belt - 1943mm	04593814AA	1

PLEASE READ ALL INSTRUCTION PRIOR TO INSTALLATION.

CALL MOPAR FOR ASSISTANCE OR FOR FRENCH/SPANISH INSTRUCTIONS 1-888-528-HEMI (4364)

Position the generator (2) and install the three generator bolts (1) and tighten the generator retaining bolts to the proper torque specification 54 N·m (40 Ft·Lbs).

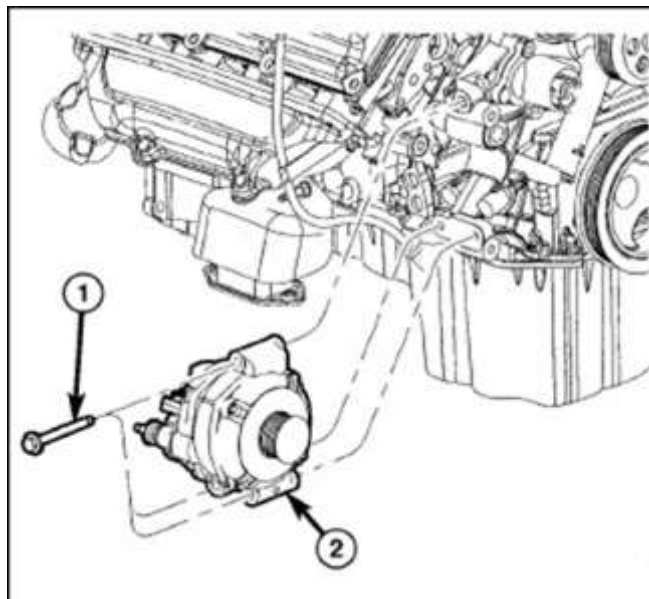

Position the generator B+ terminal eyelet to the generator output stud, install the retaining nut (3) and tighten to the proper torque specification 14 N·m (10 Ft·Lbs).

Install the insulator cover (2) onto the B+ output terminal.

Snap the field wire connector (1) into the rear of the generator.

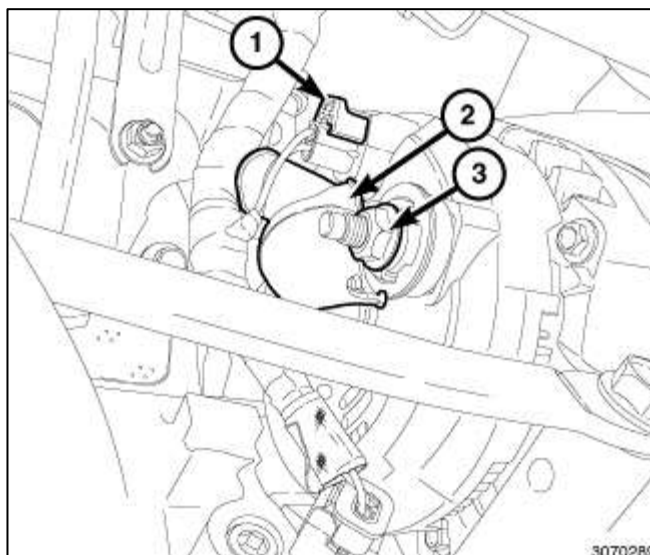

Install the smooth idler pulley (1). Tighten the idler pulley bolt (2) to the proper torque specification 29 N·m (21 Ft·Lbs).

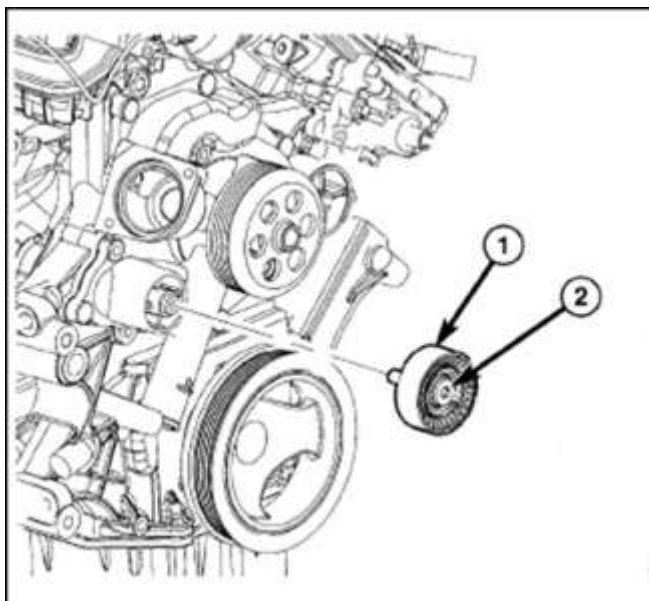

Align the locator tang and install the belt tensioner. Tighten the tensioner bolt (3) to the proper torque specification 41 N·m (30 Ft·Lbs).

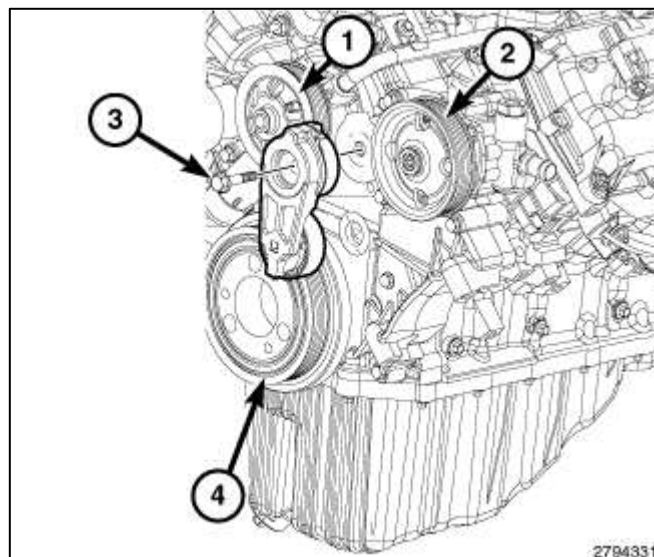

Install the grooved idler pulley (4). Tighten the idler pulley bolt (5) to the proper torque specification 29 N·m (21 Ft·Lbs).

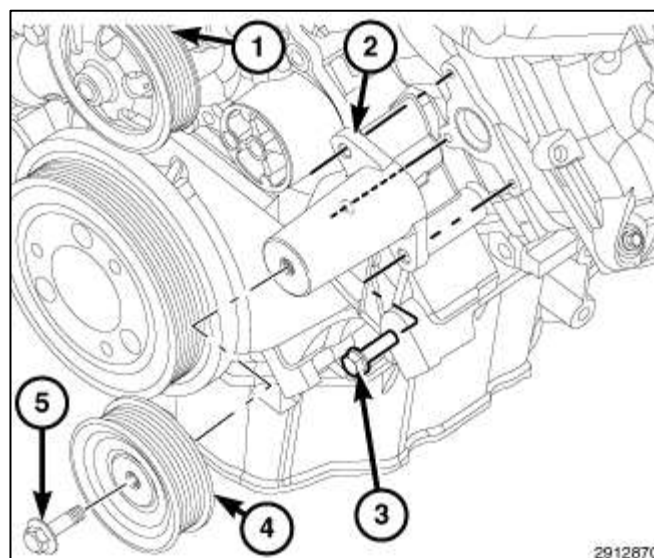

NOTE: When installing accessory drive belt onto pulleys, make sure that belt is properly routed and all V-grooves make proper contact with pulleys.

Position the drive belt (2) over all pulleys except for the water pump pulley (7).

Rotate the tensioner (8) **clockwise** and slip the belt (2) over the water pump pulley (7).

Gently release tensioner (8).

