



**LS COIL COVERS
BB CHEVY REPLICA
P/N 242-1**

PARTS LIST:

QUANTITY	DESCRIPTION
2	COIL COVERS
10	SNAP GROMMETS
8	BALL STUDS
8	WASHERS
1	OPTIONAL, OIL FILL ADAPTER TUBE (WITH O-RING)
1	OPTIONAL, OIL FILL CAP (WITH O-RING)
1	DECAL FOR STOCK OIL FILL CAP
1	WARRANTY STATEMENT
1	PRODUCT INSTRUCTIONS

APPLICATIONS:

LS2, LS3, & LS7 engines (many applications will require trimming for fitment)

APPLICATION FITTING:

The covers will fit directly on some engines, but because accessories like alternators and A/C compressors are located in different positions, trimming may be required. Trimming is easiest with a rotary trimming tool and belt sander or similar. For most applications, installation will be easier if the rear of each cover is opened as shown in **Figure 1**. Position the covers on the engine to make certain the correct end is trimmed for each cover.



Figure 1

If used with the factory fuel injection, the required area to trim for the fuel line is located on the inside of the cover (**Figure 2**). Keep in mind only one cover will need this modification (**Figure 3**).

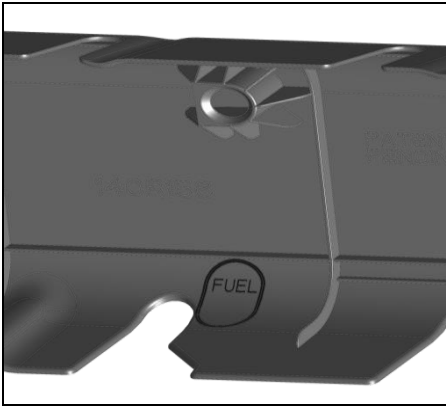

Figure 2

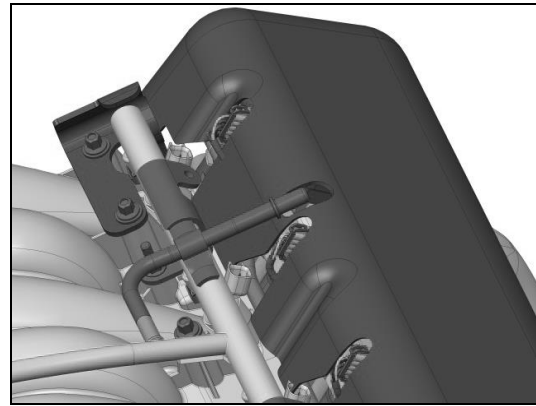

Figure 3

EXTREME HEAT:

WARNING! The cover material may melt if exposed to extreme heat. Engines with more than stock performance may produce greater exhaust heat. For these applications, trimming covers away from the exhaust is recommended.

CUSTOM PAINTING:

NOTE: Covers will have chemical residue from the manufacturing process that must be thoroughly removed before paint is applied. Trim covers to fit **BEFORE** painting.

NOTE: Solvents from the painting process can temporarily soften plastic. Heating during the curing process is not recommended. Painted covers should fully air dry on a flat surface before installation.

Holley Coil Covers are intended to be custom painted to complement the application and the individual's preference. There are numerous ways to finish these cover, two of which are described below. If you are not comfortable finishing the covers yourself, please seek professional assistance.

Do-It-Yourself Method:

1. **Clean and prepare** - Clean thoroughly using hot water, Dawn ® (or equivalent dish soap), and a Scotch-Brite™ pad (3M 7447). When this step is complete, the covers should have a dull finish over the entire surface.
2. **Clean for finish** - Use Windex® (alcohol based) or rubbing alcohol to clean the entire cover and wipe dry.
3. **Apply adhesion promoter** - Use a good quality adhesion promoter, such as Kleanstrip® ETP123B (Bulldog Aerosol), which can be found at a local parts stores. Follow the manufacturer's instructions for application.
4. **Primer coat (optional)** - Some top coat colors will not hide the black color of the raw covers well. In some cases, use of a gray primer will make top coating easier. Follow the manufacturer's instructions for application.
5. **Apply top coat** - Use a good quality top coat. The adhesion promoter applied in step 3 will allow any common paint to work as a top coat. Always paint above 65° F.

Professional Method:

**This method requires many variables not described below and should only be attempted by trained experienced paint/body shop personnel.*

1. **Clean and prepare** - Clean the cover with a wax and grease remover. If possible, leave the covers out in sun light or under heat for 30 minutes to help sweat out the silicone from the covers.
2. **Surface fill** - If the covers' surfaces are acceptable, and filler work is not required, skip to step 3. If filler is required, block sand the top of the covers with 80 grit. Apply filler of your choice.
3. **Finishing** - Sand the covers with 320 grit and apply adhesion promoter followed by an epoxy primer and finish coat.

INSTALLATION:

1. First remove any factory cosmetic covers that would interfere with installation.
2. The factory oil fill tube must be removed. There is a locking tab that is accessible from the inside of the tube. A pick or small flat screwdriver can be used to lift the tab and release the lock. Another option is to remove the valve cover and release the lock from the underside. Refer to the Holley supplied oil fill tube for an example of the tab's location and function.

OIL FILL OPTIONS:

The oil fill can be configured in two ways for LS3 and LS7 engines. LS2 engines should only use the 1st option.

1. Fill cap under cover

- A. For a clean look, the supplied fill cap can be used directly in the valve cover, under the coil cover (**Figure 4**). To add oil, the cover can be removed. Use extra care when removing cover in very low temperatures, as plastic may become brittle.

NOTE: For LS2 engines, use the original fill cap.

2. Fill cap outside of cover

- A. The supplied fill tube adapter and original fill cap can be installed to provide easier access when adding oil (**Figure 5**).
- B. Use an 1-3/4" hole saw in the location marked on the inside of the covers intended for the passenger'S side. The center pilot is marked and should be first drilled with a 1/8" or smaller bit to better center the hole saw (**Figure 6**).
- C. After final assembly, tighten the original cap in the fill tube and place the supplied decal with the Holley text oriented to the engine (**Figure 7**). Prior to applying the decal, thoroughly clean the fill cap and make certain the temperature is greater than 50°F (10°C).

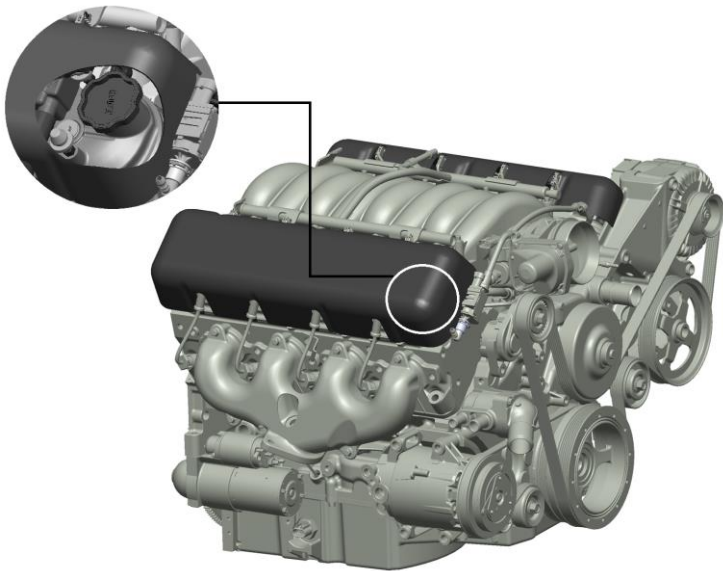

Figure 4

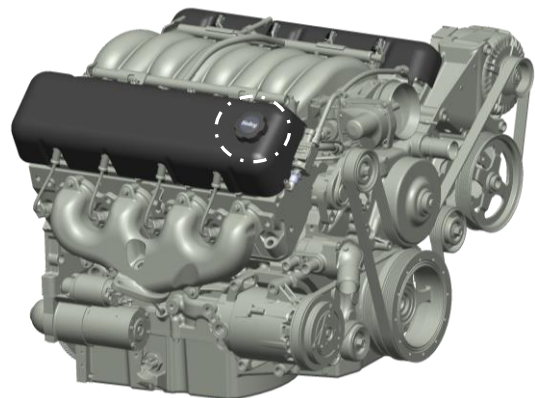

Figure 5



Figure 6



Figure 7

Install the (x10) snap grommets in bottom side of cover's sockets (**Figure 6**). After installing each grommet, rotate it in the socket to confirm it is fully seated.

PLACE SUPPLIED BALL STUDS AND WASHERS AS SHOWN BELOW:

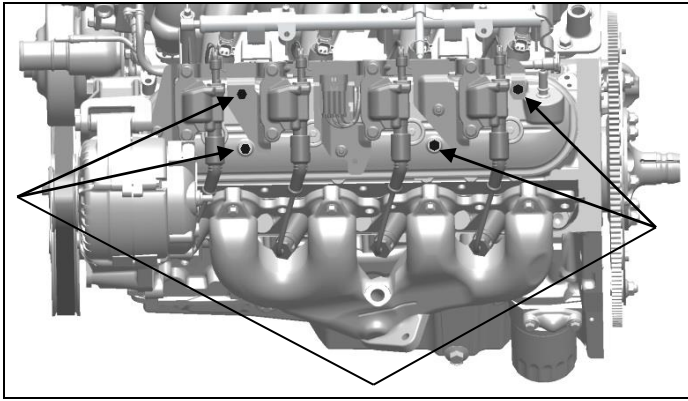

Driver's Side

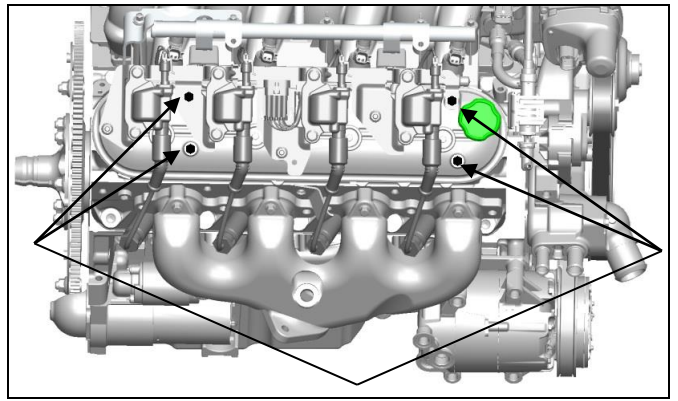

Passenger's Side

When first installing the covers, the fuel injectors will need to be rotated slightly to align with the notches in the cover. This can be easily done by hand as the injectors will rotate in their O-ring sockets. The wiring harness will need to be adjusted to align with the notches and sides of the covers. Slowly work the cover down until the grommets snap onto the ball studs. Press directly above each grommet to snap into place.

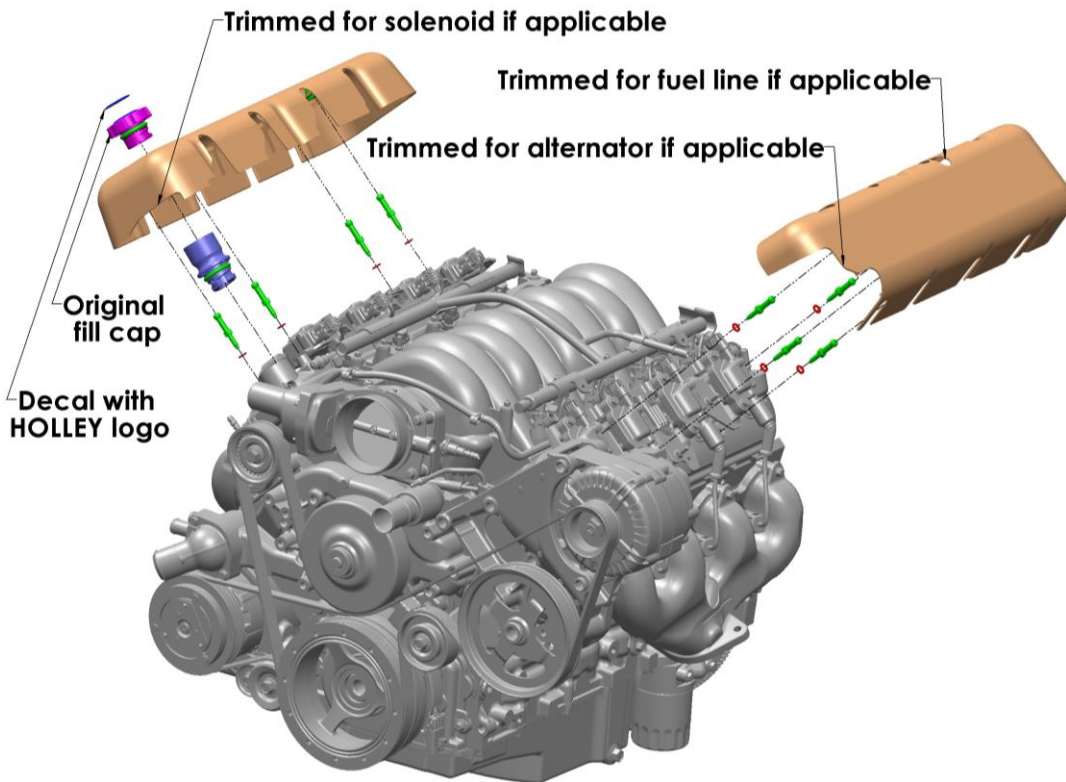

Fill cap outside of cover shown

Holley Technical Support
Phone: 1-270-781-9741
www.holley.com

© 2011 Holley Performance Products, Inc. All rights reserved. Tous Droits Réservés.

199R10568
Revision Date : 4-24-20