



DELTA FORCE

COLD AIR INTAKES
BY FLOWMASTER

Installation Instructions for: SYSTEM #615147 2015-2017 FORD F-150 TRUCKS WITH 5.0L ENGINES

NOT LEGAL FOR SALE OR USE ON ANY POLLUTION-CONTROLLED MOTOR VEHICLE IN CALIFORNIA OR IN STATES THAT HAVE ADOPTED CALIFORNIA EMISSION PROCEDURES.

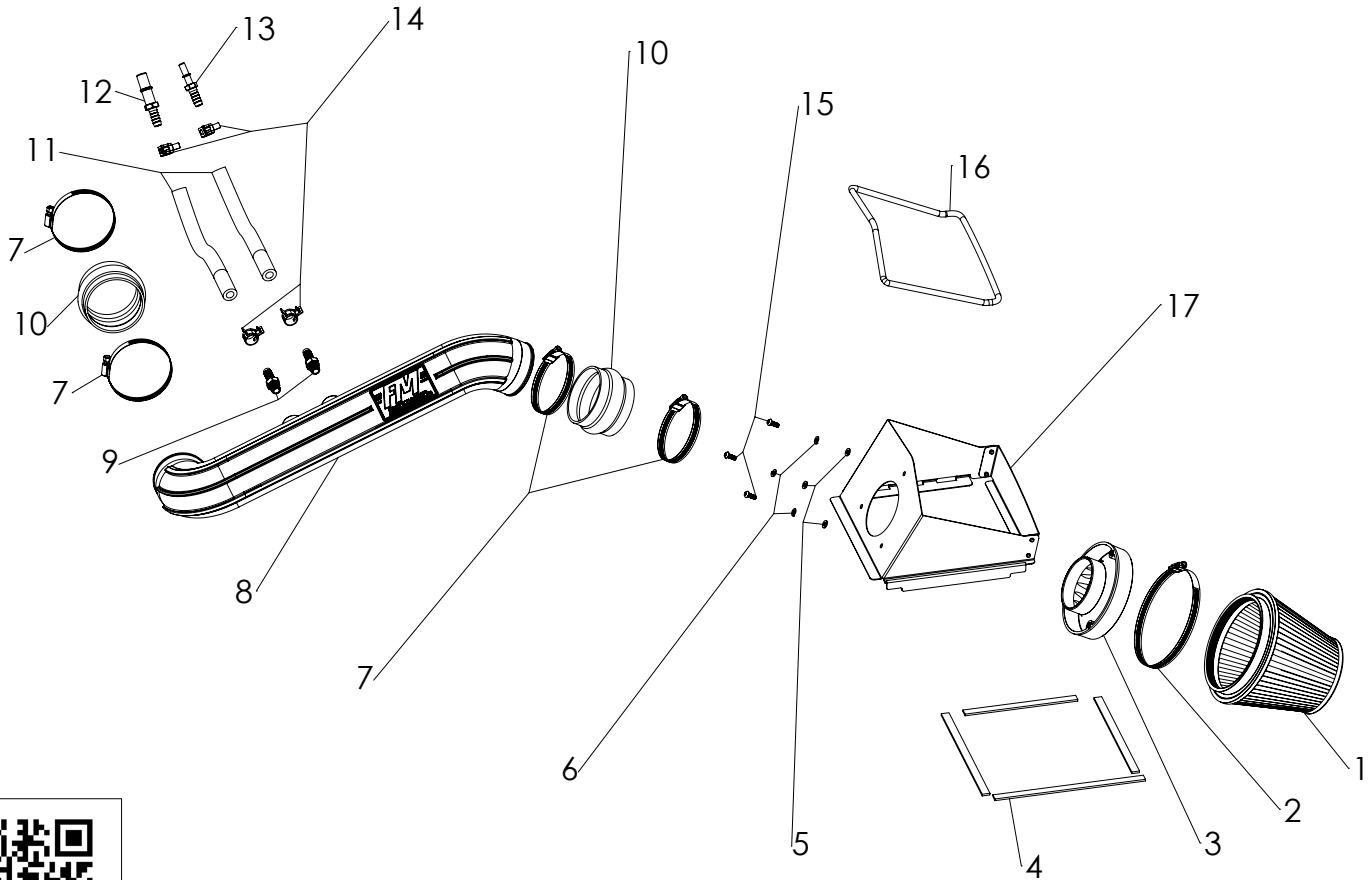

Watch our installation video on YouTube

REV. 07/12/17

ITEM NO.	PART NUMBER	DESCRIPTION	QTY.
1	AF1003	FILTER, AIR 6.625" HIGH x 6" FLANGE	1
2		#104 HOSE CLAMP, 4.125 - 7"	1
3	AF6001	3.5" x 6" AIR FILTER ADAPTER	1
4	49000067	1/8" x 1/2" ADHESIVE SEAL STRIP	1
5	HW319	M6 FLAT WASHER	3
6	HW318	M6 SPLIT LOCK WASHER	3
7	MC350H	#56 HOSE CLAMP, 3-1/16" - 4"	4
8	AF2023	MOLDED INTAKE TUBE, 15-17 F-150, 5.0L	1
9	AF4011	1/2" BARB TO 1/4" NPT MALE STRAIGHT	2

ITEM NO.	PART NUMBER	DESCRIPTION	QTY.
10	AF4019	3.5" ID x 2.5" L RUBBER COUPLER, HUMP	2
11	49000064	0.5" ID x 0.91" OD FUEL HOSE	1 (cut in 2)
12	AF4043	5/8" QUICK CONNECT TO 1/2" HOSE BARB	1
13	AF4042	3/8" QUICK CONNECT TO 1/2" HOSE BARB	1
14	MC003P	1/2" HOSE PINCH CLAMP	4
15	HW244	M6 x 1.0 x 16MM SCREW	3
16	49000061	PUSH ON VINYL HEAT SHIELD GASKET	1
17	AF3023	HEAT SHIELD, 15-17 FORD F-150 5.0L V8	1

REVIEW THE INSTRUCTIONS AND VERIFY THE KIT CONTENTS:

1. Please take a moment to read and understand these instructions before installing your Flowmaster cold air intake kit.



2. Use the parts drawing and list (front page) to verify your kit's contents.

In the unlikely event that any parts are missing, please contact FLOWMASTER Technical Support for replacements.

REMOVE THE FACTORY AIR INTAKE SYSTEM:

NOTES

- We highly recommend that you retain all factory air intake system parts.
 - Please refer to vehicle manufacturer's recommendations regarding removal of factory components.
 - Disconnecting the negative battery cable erases pre-programmed electronic memories. Write down all memory settings before disconnecting the negative battery cable. Some radios will require an anti-theft code to be entered after the battery is reconnected. The anti-theft code is typically supplied with your owner's manual. In the event your vehicle's anti-theft code cannot be recovered, contact an authorized dealership to obtain your vehicle's anti-theft code.
3. **Turn off the vehicle's ignition and disconnect the negative battery cable.**



4. Loosen the hose clamp securing the air intake duct to the airbox cover, then disconnect the intake duct from the airbox cover.



5. Release the two airbox cover clips, then remove the airbox cover and stock air filter.



6. Release the coolant overflow hose from the clip on top of the intake duct.

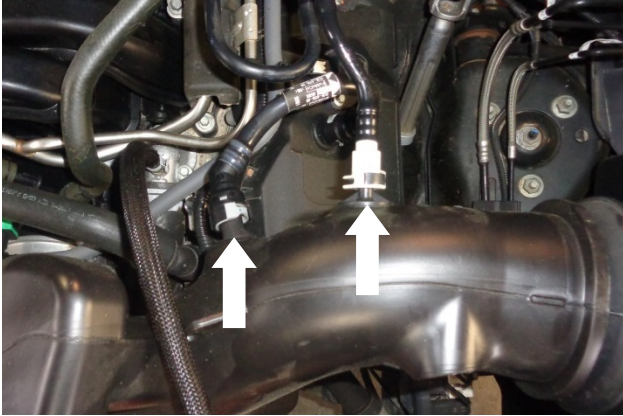

7. Disconnect the PCV and EVAP lines from the intake duct.



8. Loosen the hose clamp securing the air intake duct to the throttle body, then disconnect the intake duct from the throttle body.

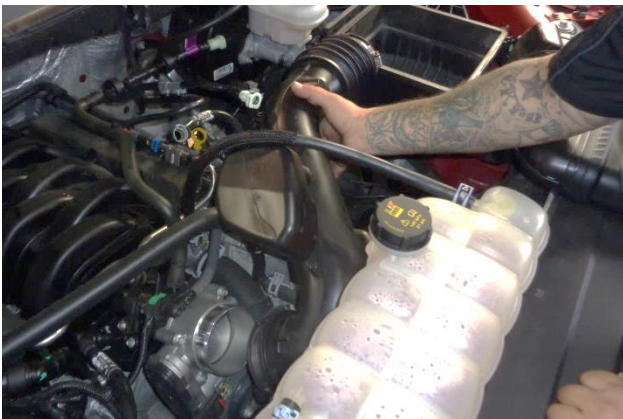

9. Carefully remove the intake duct from the vehicle.

ASSEMBLE AND INSTALL YOUR FLOWMASTER COLD AIR INTAKE SYSTEM:

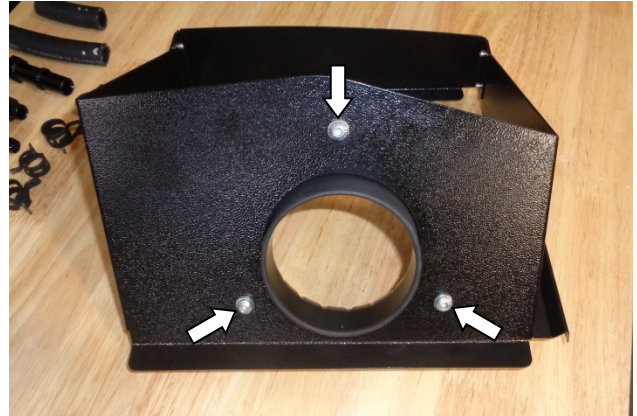

10. Assemble air filter adapter (3) to heat shield (17) using M6 screws (15), lock washers (6) and flat washers (5).



11. Attach gasket (16) to heat shield. Starting in the middle of the edge opposite the filter adapter, firmly press the gasket onto the heat shield, gradually working your way around. When you return to the start point, use metal-cutting shears to trim the gasket to length.



12. Slip two hose clamps (7) onto a coupler (10). Push the coupler onto the air filter adapter, all the way against the heat shield, and tighten the clamp.



13. Slip clamp (2) onto air filter (1), install filter on filter adapter, and tighten clamp. Cut adhesive seal strip (4) to the lengths required, and apply to the four edges of the heat shield.



14. Place the assembled heat shield on the airbox, and secure it with the two locking clips.



15. Apply 2 wraps of nylon thread tape to the threads of the two 1/2" barbed fittings (9), and install them in the intake tube (8).



16. Slip two hose clamps (7) onto the other coupler (10). Push the coupler onto the air intake tube and snug (but do not yet tighten) the clamp.

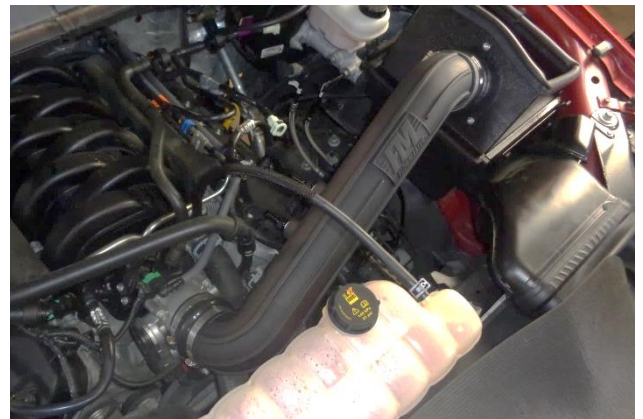

19. Install the intake tube in the vehicle. (The tube will pass under the coolant overflow line.) Push the coupling up against the throttle body opening and tighten the throttle body clamp. Then check that the tube is properly aligned in both couplings, and tighten the last two clamps.

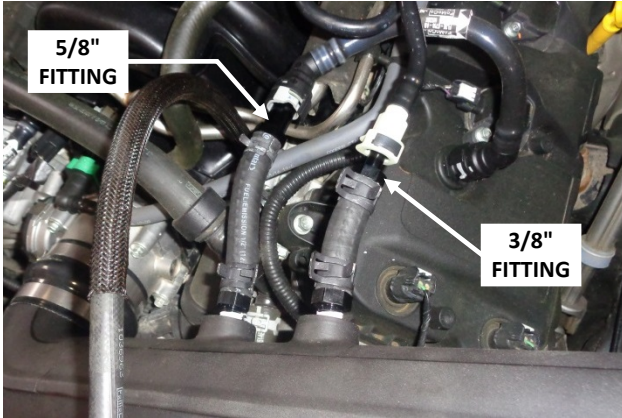

20. Cut the 1/2" hose (11) approximately in half, and clamp the 5/8" fitting (12) in one of the two hoses with a pinch clamp (14). Insert the fitting into the PCV connector, cut the hose to reach its barbed fitting on the intake duct, and secure the hose to the fitting with a pinch clamp (14). Repeat the process for the 3/8" fitting (13) and the EVAP connector.

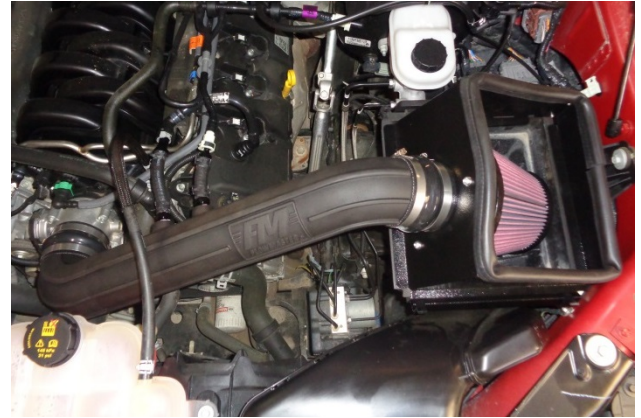

Congratulations, the installation of your FLOWMASTER cold air intake kit is now complete!