

Installation Instructions for
SYSTEM #615141
2012-2015 TOYOTA TACOMA
With 4.0L Engine

NOT LEGAL FOR SALE OR USE ON ANY POLLUTION-CONTROLLED MOTOR VEHICLE IN CALIFORNIA OR IN STATES THAT HAVE ADOPTED CALIFORNIA EMISSION PROCEDURES.

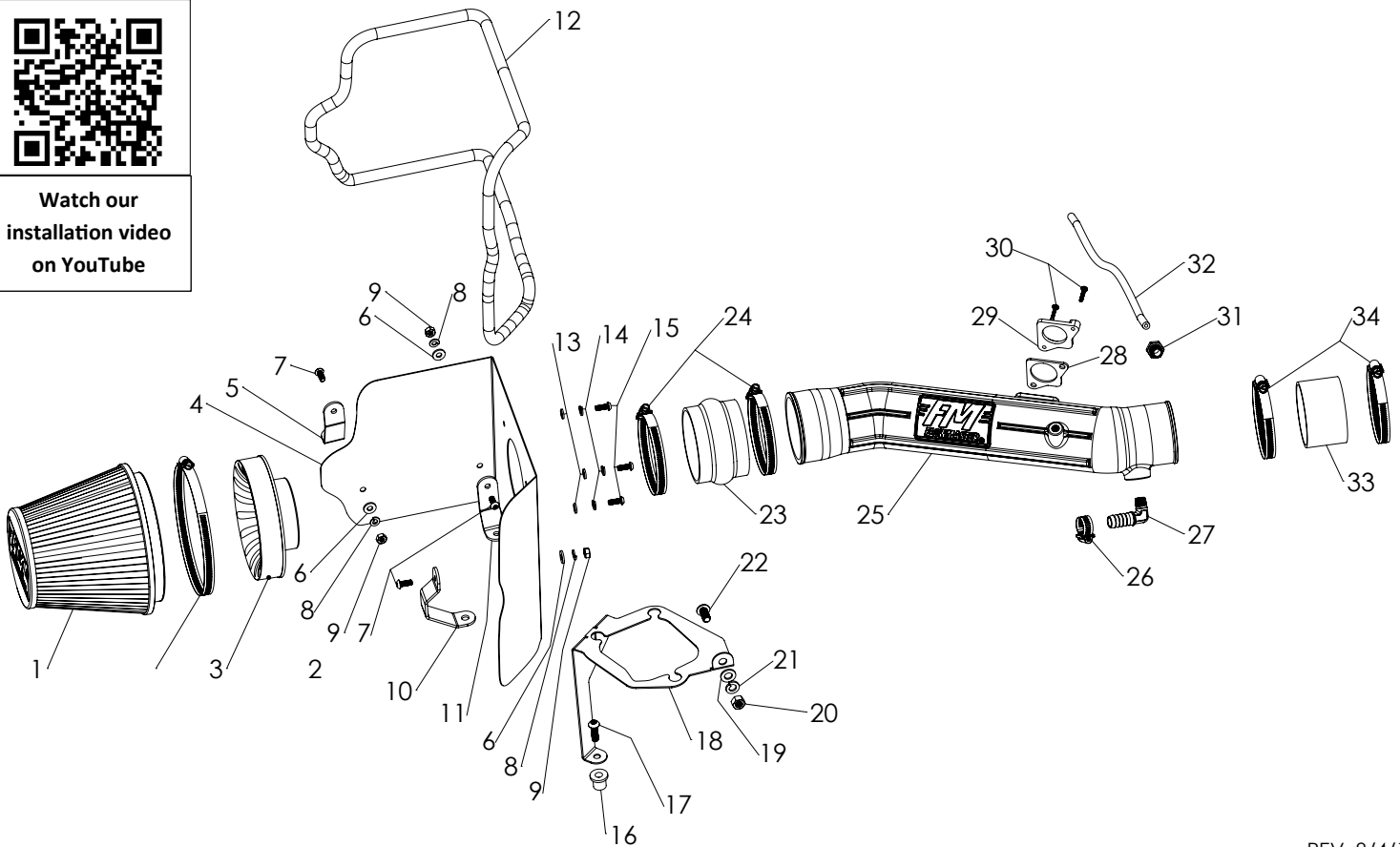

Watch our
installation video
on YouTube



REV. 8/4/17

ITEM NO.	PART NUMBER	DESCRIPTION	QTY.
1		FILTER, AIR, 6-5/8" HIGH x 6" DIA	1
2	AF1003	HOSE CLAMP, #104 (4-1/8" - 7")	1
3	AF6001	ADAPTER, AIR FILTER, 3-1/2" x 6"	1
4	AF3014	HEAT SHIELD, 12-15 TOYOTA TACOMA 4.0L	1
5	AF5022	BRACKET 1, 12-15 TOYOTA TACOMA 4.0L	1
6	HW320	FLAT WASHER, 1/4"	3
7	HW245	SCREW, 1/4"-20 x 5/8"	3
8	HW322	LOCK WASHER, 1/4"	3
9	HW115	NUT, 1/4"-20	3
10	AF5024	BRACKET 3, 12-15 TOYOTA TACOMA 4.0L	1
11	AF5023	BRACKET 2, 12-15 TOYOTA TACOMA 4.0L	1
12	49000061	GASKET, HEAT SHIELD	66"
13	HW319	FLAT WASHER, M6	3
14	HW318	LOCK WASHER, M6	3
15	HW244	SCREW, M6 x 1.0 x 16MM	3
16	HW122	WELL NUT, RUBBER, 5/16"-18	1
17	HW252	SCREW, 5/16"-18 x 1"	1

ITEM NO.	PART NUMBER	DESCRIPTION	QTY.
18	AF5025	BRACKET, AIR PUMP, 12-15 TOYOTA TACOMA 4.0L	1
19	HW316	FLAT WASHER, 3/8"	1
20	HW120	NUT, 3/8"-16	1
21	HW325	LOCK WASHER, 3/8"	1
22	HW253	SCREW, 3/8"-16 x 3/4"	1
23	AF4019	RUBBER COUPLER, FLEX 3-1/2" I.D. x 2-1/2" L	1
24	MC350H	HOSE CLAMP, #56 (3-1/16" - 4")	2
25	AF2014	INTAKE TUBE, 12-15 TOYOTA TACOMA 4.0L	1
26	MC075H	PINCH CLAMP, #8 (0.437" - 1.00")	1
27	AF4038	ELBOW, 90°, 5/8" BARB TO 1/4" NPT MALE	1
28	GA140	GASKET, MAF SENSOR ADAPTER	1
29	AF7002	ADAPTER, MAF SENSOR	1
30	HW255	SCREW, M4 x 0.7 x 20MM	2
31	AF4027	STRAIGHT FITTING, 3/16" BARB TO 1/4" NPT MALE	1
32	49000066	HOSE, VACUUM, 5/32" I.D.	24"
33	AF4034	RUBBER COUPLER, STRAIGHT, 3" I.D. x 2" L	1
34	MC314H	HOSE CLAMP, #52 (2-13/16" - 3-3/4")	2

REVIEW THE INSTRUCTIONS AND VERIFY THE KIT CONTENTS:

1. Please take a moment to read and understand these instructions before installing your Flowmaster cold air intake kit.



2. Use the parts drawing and list (front page) to verify your kit's contents.

In the unlikely event that any parts are missing, please contact FLOWMASTER Technical Support for replacements.

To simplify assembly and avoid cross-threading fasteners, identify and separate the 1/4-20 screws (item 7) (used with nuts (9)), and the M6 screws (15) (used with filter adapter (3)).

REMOVE THE FACTORY AIR INTAKE SYSTEM:

NOTES

- We highly recommend that you retain all factory air intake system parts.
- Please refer to vehicle manufacturer's recommendations regarding removal of factory components.
- Disconnecting the negative battery cable erases pre-programmed electronic memories. Write down all memory settings before disconnecting the negative battery cable. Some radios will require an anti-theft code to be entered after the battery is reconnected. The anti-theft code is typically supplied with your owner's manual. In the event your vehicle's anti-theft code cannot be recovered, contact an authorized dealership to obtain your vehicle's anti-theft code.

3. Turn off the vehicle's ignition and disconnect the negative battery cable.

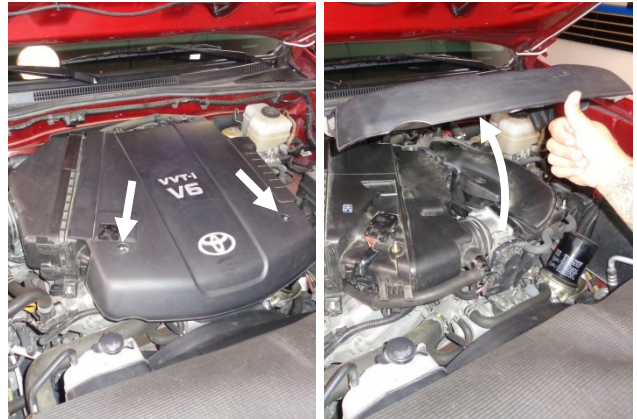

4. Remove two nuts and the engine appearance cover.

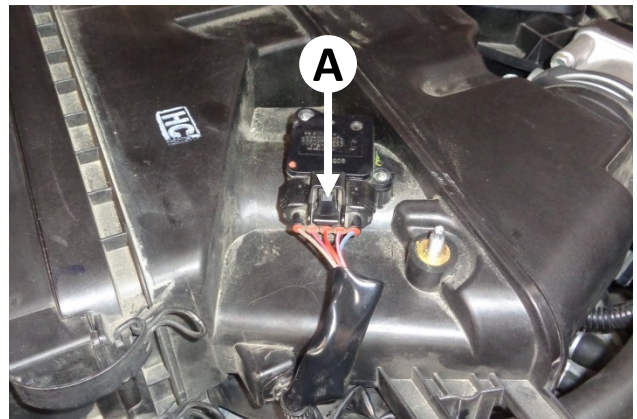

5. Disconnect the mass airflow (MAF) sensor plug by pressing the latch (A) and pulling the plug straight off the sensor.

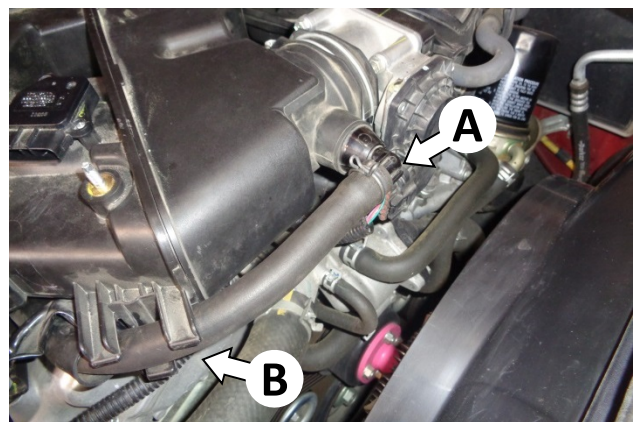

6. Disconnect the PCV hose from elbow (A) and release the hose from clips (B). Then remove the pinch clamp from the hose.

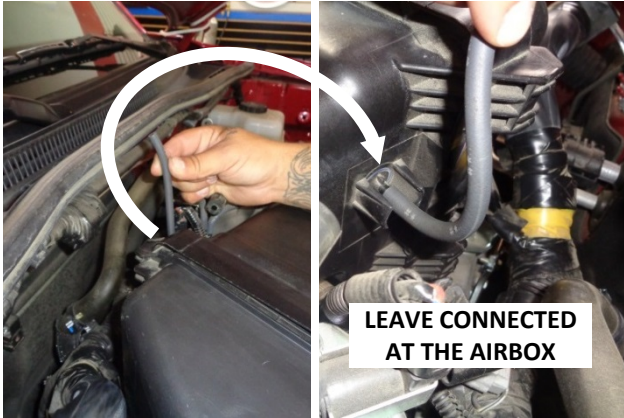

7. At the back of the airbox, disconnect the 1/8" vacuum hose from the fuel pressure regulator. (The hose will not be re-used, so it may be left connected to the airbox.)

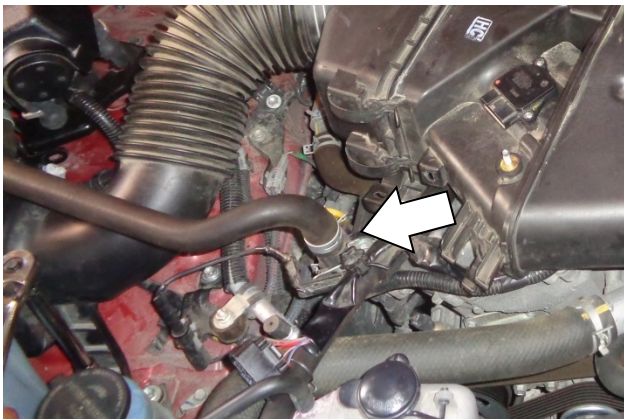

8. Disconnect the secondary air hose from the valve. **Leave the clamp on the hose for use at Step 31.**

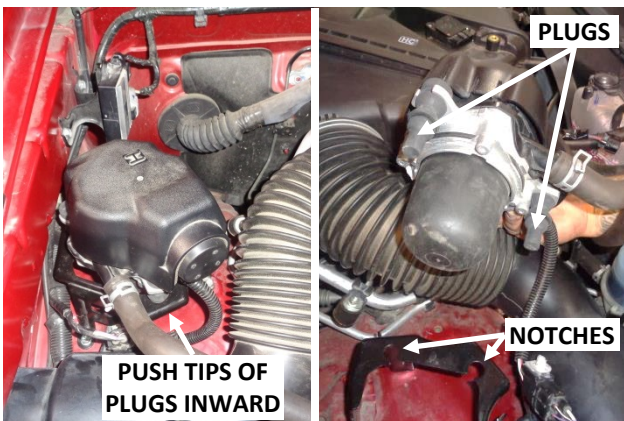

9. The secondary air pump is secured to its bracket with three rubber plugs. Under the bracket, push the tip of each plug inward to release it from its notch. When all three plugs are released, carefully set the pump on top of the windshield washer fluid reservoir.

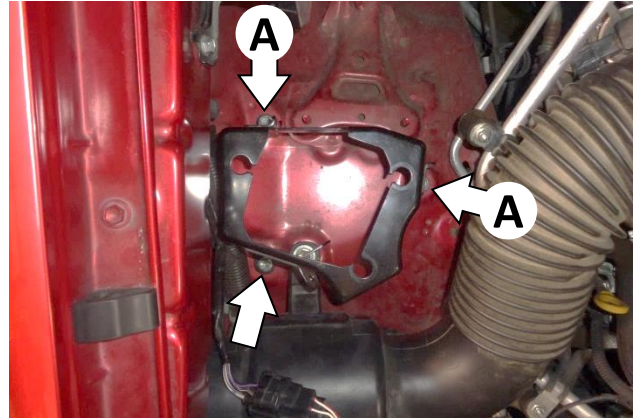

10. Remove the 3 bolts and the secondary air pump bracket. **Set the two rearmost bolts (A) aside for use at Steps 33 and 34.**

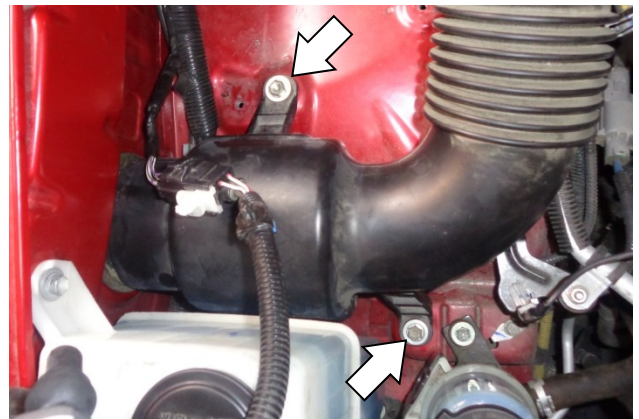

11. Remove the 2 bolts securing the air intake duct to the fender.

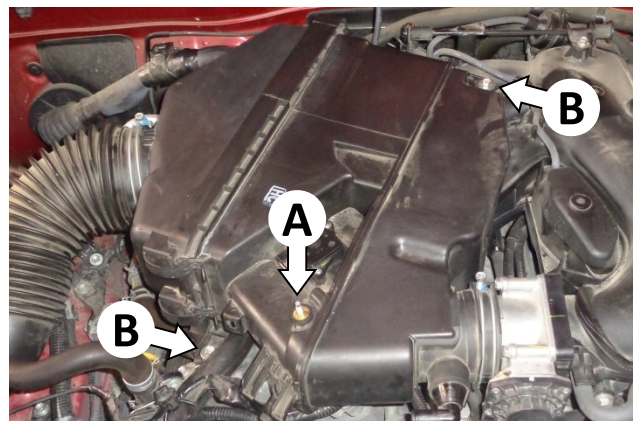

12. Remove the mount stud (A) (for the engine appearance cover) from the airbox and **retain for use at Step 21**. Then remove the two airbox mount bolts (B).



13. Loosen the hose clamp securing the airbox to the throttle body.



14. Carefully remove the assembled intake duct and airbox from the vehicle.



15. Remove the mass airflow (MAF) sensor from the airbox. **Do not remove the o-ring from the sensor.**

ASSEMBLE AND INSTALL YOUR FLOWMASTER COLD AIR INTAKE SYSTEM:

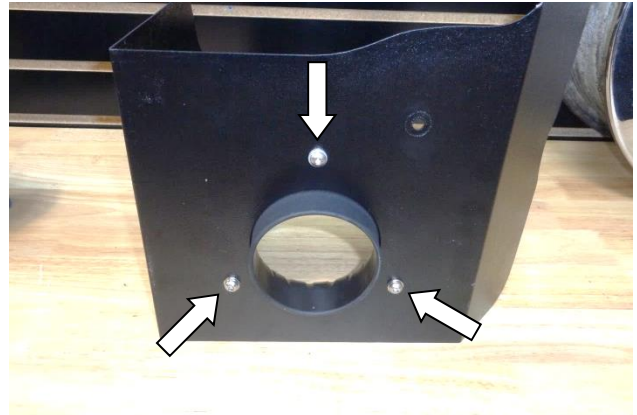

16. Assemble air filter adapter (3) to heat shield (4) using M6 screws (15), lock washers (14) and flat washers (13).

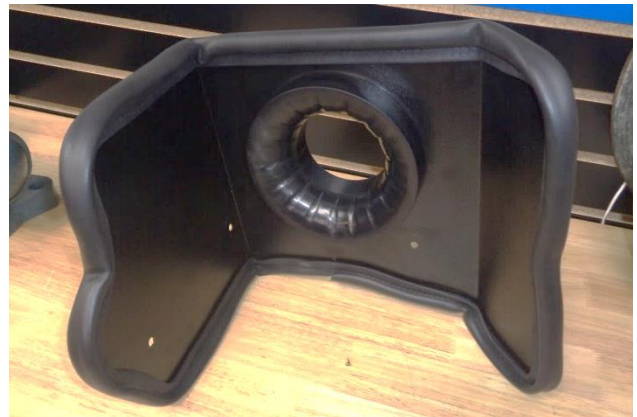

17. Attach gasket (12) to heat shield. Starting under the filter adapter, firmly press the gasket onto the edge, gradually working around the heat shield. When you return to the starting point, trim the gasket to fit using metal-cutting shears.

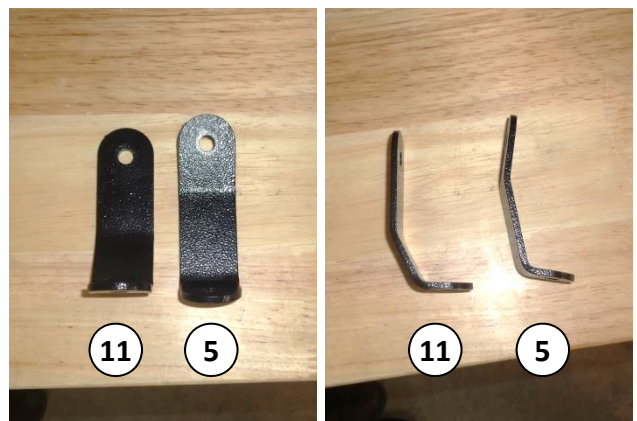

18. Heat shield brackets (11) and (5) look similar. Identify them as shown above.



19. Attach bracket (5) to the heat shield using ¼-20 screw (7) (on the bracket side), and flat washer (6), lock washer (8) and nut (9) (on the heat shield side). **Do not fully tighten the fasteners at this time.**

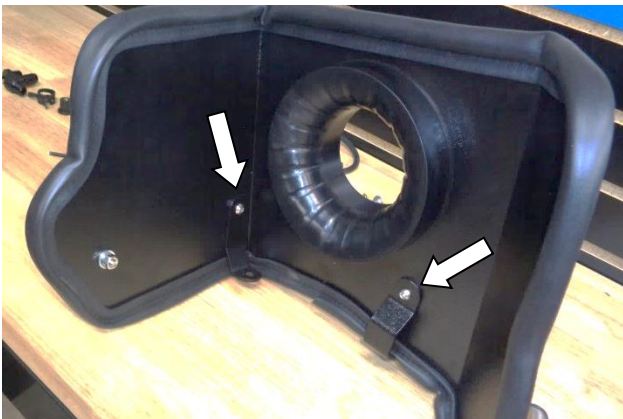

20. Attach brackets (11) and (10) to the heat shield using ¼-20 screws (7) (on the bracket side), and flat washers (6), lock washers (8) and nuts (9) (on the heat shield side). Note that bracket (10) passes under the edge of the heat shield. **Do not fully tighten the fasteners at this time.**



21. Install the engine appearance cover mount stud (**removed at Step 12**) in air intake tube (25).

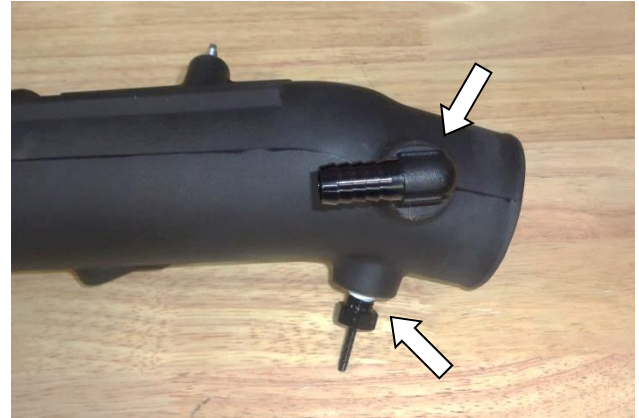

22. Apply 2 wraps of nylon thread tape to the 5/8" elbow (27) and the 3/16" straight fitting (31), and install them in the intake tube, orienting the elbow as shown.

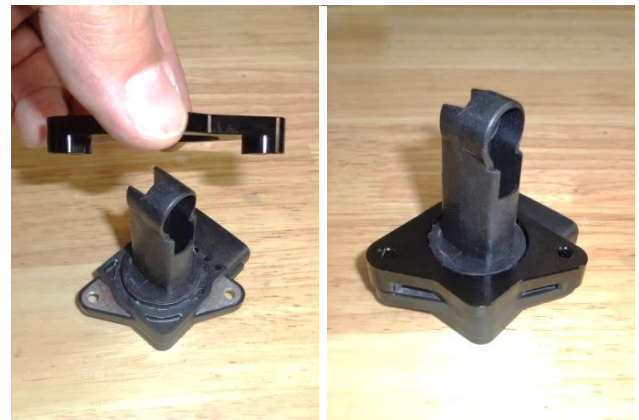

23. Install MAF sensor adapter (29) as shown. (Lightly lubricate the sensor o-ring if required.)



24. Install MAF sensor gasket (28) on the sensor and adaptor, then install the sensor in the intake tube using M4 screws (30).



25. Install the 2 small hose clamps (34) on the straight coupler (33), and install the coupler on the throttle body end of the intake tube. **Do not tighten clamps at this time.**



26. Install the 2 large hose clamps (24) on the flex coupler (23), and install the coupler on the filter end of the intake tube. **Do not tighten clamps at this time.**



27. Assemble the heat shield and intake tube, pushing the coupler flush against the heat shield. Tighten the clamp at the filter adapter, but **only snug the other clamp at this time.**



28. Insert rubber well nut (16) in the hole at the front corner of the washer fluid reservoir. (Wetting the well nut with soapy water may ease insertion.)

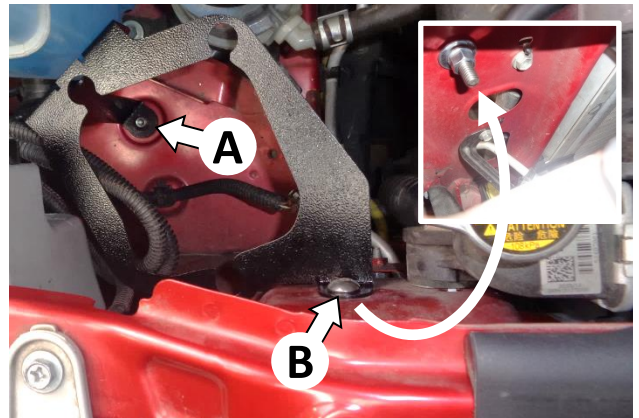

29. Set the new air pump bracket (18) in place. Fasten foot (A) using 5/16-18 screw (17). Fasten front tab (B) using the 3/8-16 screw (22) (on the bracket side), and the 3/8" flat washer (19), lock washer (21) and nut (20) (on the front side of the radiator support).

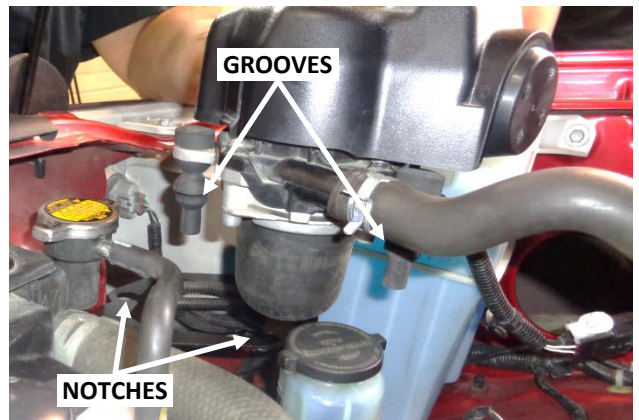

30. Mount the secondary air pump in the bracket by pushing the groove of each mount plug into the corresponding notch. (Wetting the plugs with soapy water may ease insertion.)

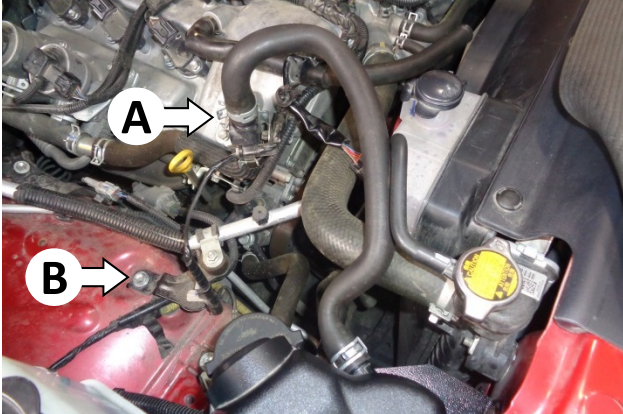

31. Reconnect the secondary air hose to the air valve (A). Adjust the hose so that it does not kink and secure it with the pinch clamp. Then **remove bolt (B) for use in at Step 33.**

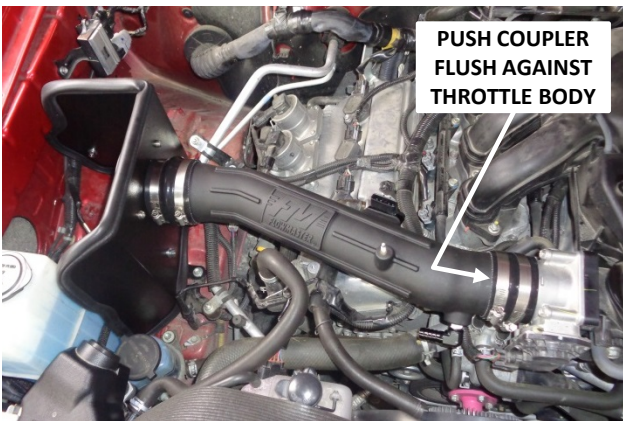

32. Install the assembled heat shield and intake tube in the vehicle, pushing the coupler flush against the throttle body. (Some wiring on the fender may pass under / around the heat shield gasket.) Tighten the clamp at the throttle body, but **only snug the other clamp at this time.**

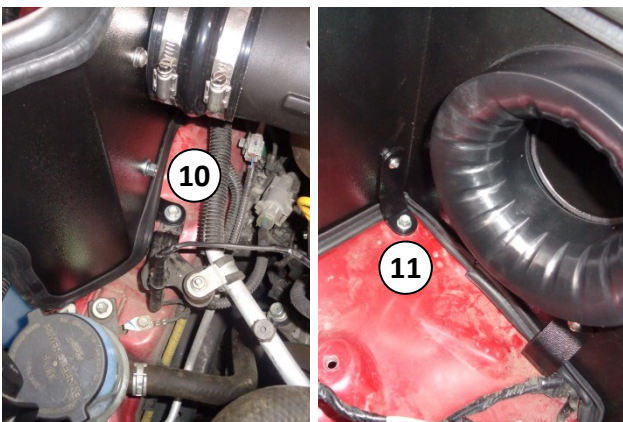

33. Use the stock bolt removed at **Step 31** to fasten bracket (10) to the vehicle. Use the stock bolt removed at **Step 10** to fasten bracket (11) to the vehicle.

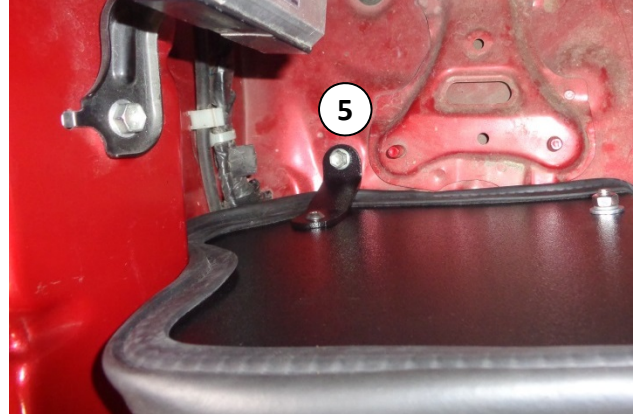

34. Use the stock bolt removed at **Step 10** to fasten bracket (5) to the vehicle. **After all 3 heat shield brackets are bolted down, tighten each bracket's fasteners to the heat shield.**

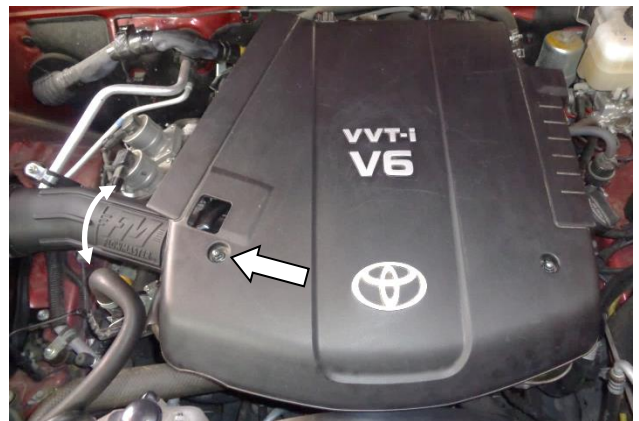

35. Temporarily install the engine appearance cover. Rotate the intake tube as required to align the stud with the hole in the cover, then remove the cover and tighten the last 2 clamps on the intake tube.

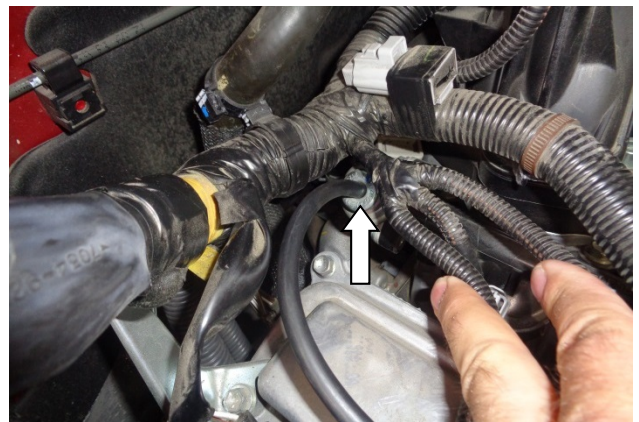

36. Push one end of the 5/32" vacuum hose (32) onto the fuel pressure regulator.

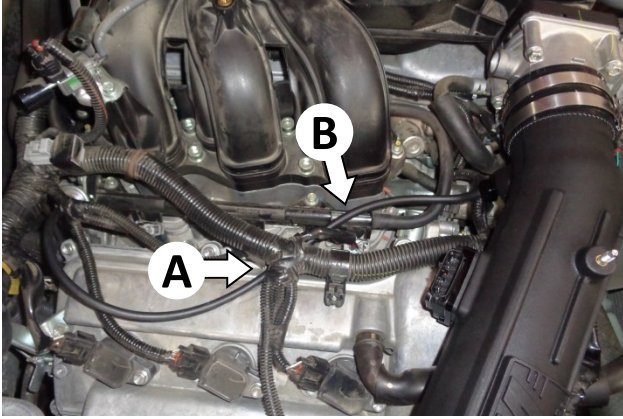

37. Route the vacuum hose under the wire bundle (A) and over the fuel rail (B) to the 3/16" barbed fitting in the intake tube. Cut the hose to length and push it onto the barbed fitting.



38. Push the PCV hose onto the barbed elbow and secure with pinch clamp (26).

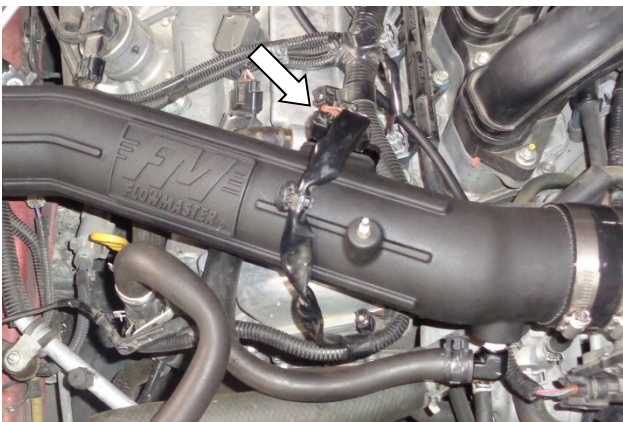

39. Connect the MAF sensor plug to the sensor and check for security.



40. Place clamp (2) on air filter (1), install the filter on the filter adapter, and tighten the clamp.



41. Reinstall the engine appearance cover and secure it with the stock nuts.



Congratulations, the installation of your FLOWMASTER cold air intake kit is now complete!