



HOLLEY INTAKE ELBOW FOR 4150 CARB FLANGE INSTALLATION INSTRUCTIONS 199R11185

PRODUCT DESCRIPTION:

This intake elbow is designed for either GM, LS style (300-240), or 1986-1993 Ford 5.0L style (300-240F) throttle valves up to 105mm. It will fit intake manifolds with square bore (4150 style) flange. Provision for a LS3 style MAP sensor is included. For customers not using a MAP sensor, a billet cover is supplied. This unit also includes two 1/8 NPT ports, one 1/4 NPT port, one 3/8 NPT port. A modified hood may be required for use with some vehicles.

DIMENSIONS:

- Overall Height: 5.12"
- Inlet Opening Size: 105mm
- Throttle Flange Angle: 100 Degrees

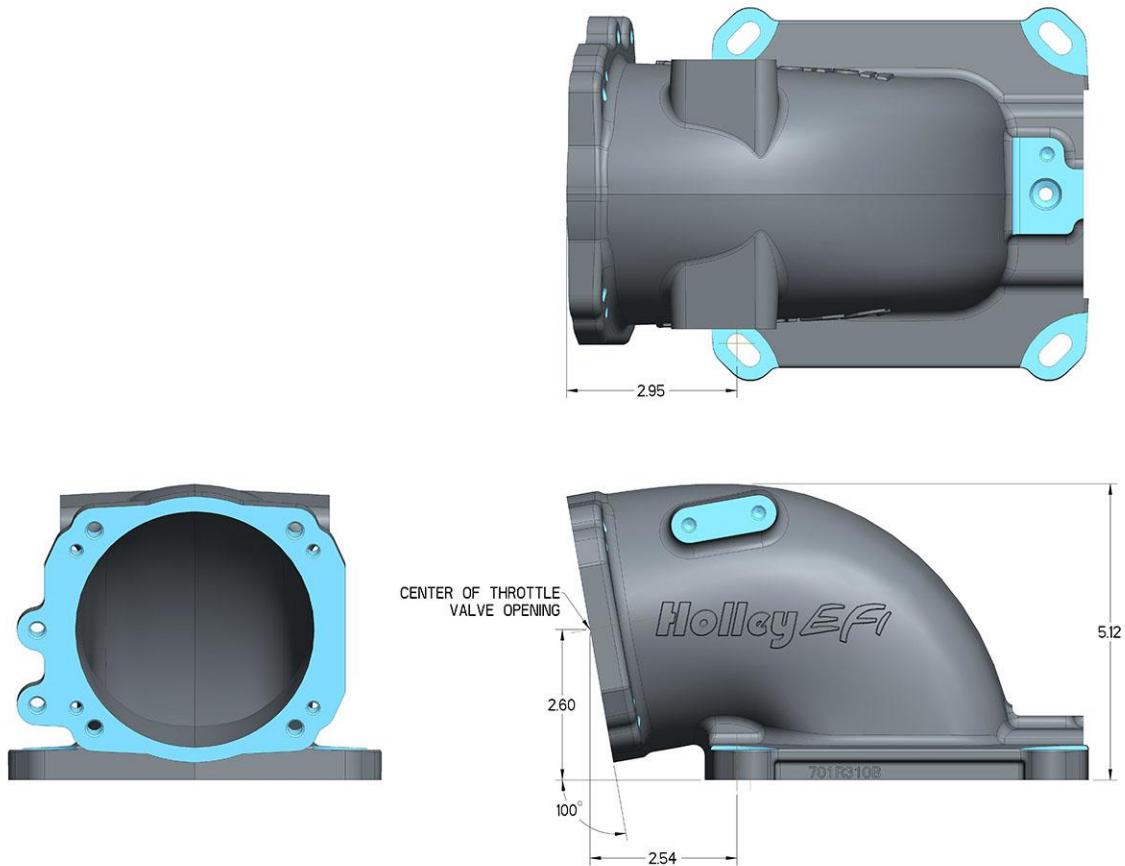

300-240F is shown – 300-240 is similar

INSTALLATION KIT CONTENTS:

Qty	Description
4	5/16 Studs
4	5/16 Washers
4	5/16-24 Hex Nuts
2	Plug, 1/8 NPT
1	Plug, 1/4 NPT
1	Plug, 3/8 NPT

Qty	Description
1	Screw, 1/4-20 x 1 1/2 Point Cap, MAP Sensor Mounting
1	Washer, 1/4", MAP Sensor Mounting
1	Installation Instructions
1	Warranty Card
1	Gasket, Carb Flange
1	Gasket, LS Throttle Body (300-240)
1	Gasket, Ford Throttle Body (300-240F)

MAP SENSOR PORT COVER KIT 300-251 CONTENTS:

Qty	Description
1	MAP Sensor Port Cover
1	O-Ring
1	Washer, 1/4"
1	Screw 1/4-20 x 3/4"
1	Warranty Card

INTAKE ELBOW INSTALLATION INSTRUCTIONS:

1. Mount intake elbow to intake manifold using supplied carb flange gasket, studs, washers, and nuts.
2. Assemble throttle valve to elbow. After assembly, have an assistant fully actuate the throttle controls from inside the vehicle. Open and close the throttle several times to ensure that it operates smoothly with no binding or sticking.

DANGER! A sticking throttle may result in uncontrolled engine or vehicle speed. This could cause property damage, personal injury, or death. A sticking throttle may be caused by improperly installed throttle cables, lack of clearance for any of the throttle linkage, or by a binding throttle linkage. Check all throttle cables for proper installation and alignment and actuate the throttle to check for any potential binding or clearance problems. Repair any problems before continuing.

3. If using a MAP sensor, apply a silicone lubricant to the O-ring prior to installation.
4. Assemble fittings or plugs into vacuum ports as needed.

MAP SENSOR PORT COVER INSTALLATION INSTRUCTIONS:

1. Apply a silicone lubricant to supplied O-ring and gently press onto cover.
2. Using the supplied screw and washer, assemble to MAP sensor port on intake elbow.

Technical Support: 1-866-464-6553

199R11185

Revision Date: 1-28-19