

SUPER DAMPER

Required tools

Damper Installation Tool Torque Wrench (ft/lbs & in/lbs)
Torx T-40 Plus Bit Blue Loctite 242 or similar grade

Additional tools required depending on damper

Torx T-45 Plus Bit 3/8-12 point Socket Red Loctite
Torx T-35 Plus Bit 5/16-12 point Socket Allen Wrench Sockets



**** FOR CHEVY LS DAMPERS SEE PAGE 3 ****

Assembling the Damper to the Hub

NOTE: ALL BOLT HOLES MUST HAVE A BOLT INSTALLED!

NOTE: DAMPER HUB TO DAMPER SHELL ASSEMBLY FIT IS HELD TO AN EXTREMELY CLOSE TOLERANCE!

1. The Super Damper shell assembly is indexed to the crank hub with an offset hole marked by an indent dimple on the front of the hub and on the front face decal with an arrow. These must be aligned for proper assembly.

NOTE: SOME DAMPERS AND HUBS ARE ALREADY ASSEMBLED

For part numbers 917060, 917062, 917080, 917740, 917780, 917781, 917788, any 5.5" damper or 1-piece damper, **DO NOT** disassemble damper for installation. Install as a complete damper. Remove pulley bolts, install pulley, apply Loctite and torque all bolts.

Proceed directly to Installation of Damper and Hub Assembly section.

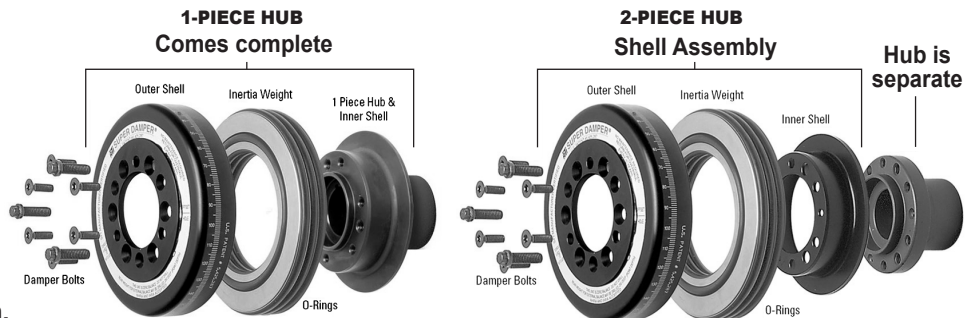

2. Start the damper onto the hub. If you are exactly straight, it will slip right on. You may need to use your palms or fists to get it to go all the way back. If the shell assembly is on enough to start two 5/16" countersunk flat head bolts, do so 180° apart and "snug" them slightly opposite of each other so the shell will "walk" on. The shell assembly will slip on as the bolts straighten it out.
3. Start the remaining (7), (4) or (2), (depending on pulley bolt configuration dampers) countersunk flat head screws in the remaining tapered holes. Draw the damper assembly onto the hub evenly. Torque the six (6) flat head screws to 16 ft/lbs. For any 5 1/2" damper with 1/4"-20/28 bolts, torque to 120 in/lbs utilizing Loctite. Be sure to use Blue Loctite 242 and the **proper Torx-40 Plus Bit** in most cases. T40 PLUS is not a standard Torx bit. Using a standard bit will ruin the head of the bolt and make it nearly impossible to ever get the bolts out.

Installation of the Damper and Hub Assembly to the Crankshaft

1. Inspect your crankshaft for burrs, nicks, etc. and file to clean up.
2. Stone or file a slight radius on the end to break the sharp edge.
3. Inspect your key and replace as necessary.

KEYS	STEPKEY
3/16 x 3/16 x 2-7/8".....916325	3/16" to 1/4" Step key for reducing cranks
1/4 x 1/4 x 2-7/8".....916326	w/ 1/4" keyway to 3/16".....918992
1/8 x 1/8 x 5-3/4" (Mandrels)916327	

4. It is highly recommended that you use anti-seize lubricant on the crankshaft before hub installation.

5. Press fit of the hub to the crankshaft is vital to transfer harmonics to the damper assembly.

Recommended press is as follows:

Crankshaft OD	Interference	Crankshaft OD	Interference
1.0000" - 1.2500"	----- .0009" to .0012"	1.6010" - 2.0000"	----- .0006" to .0008"
1.2510" - 1.3750"	----- .0008" to .0011"	2.0010" - 2.5000"	----- .0005" to .0007"
1.3750" - 1.6000"	----- .0007" to .0009"		

GM cranks are typically to tolerance +/- .0001 (one ten thousandth). If you are using an OEM GM crank you can hone the damper hub as follows:

Big Block:-----hone to 1.5993" +/- .0001"
 Small Block:-----hone to 1.2453" +/- .0001"

On all other cranks, the crank must be checked with micrometers and the hub with a dial bore gauge to verify fit. Most OEM cranks are held to +/- .0002" while most aftermarket cranks are held to +/- .0005." Hub bores are tight to accommodate aftermarket cranks and most hubs will require honing. ATI can perform this service for \$40.

DO NOT HONE ALUMINUM HUBS—SEE PAGE 4 FOR SPECIAL INSTRUCTIONS

- Rear mounted accessory pulleys must be placed on the rear of the hub before installation, insert (3) 5/16" or 3/8" pulley bolts through the front pulley, through the damper body, and through the 3/8" tapped holes in the hub. If the damper is supplied with 3/8" rear pulley bolts (i.e. supercharger versions), they will pass through a hole clearanced for this size bolt in the hub. These bolts will thread into the pulley and draw it up tight to the rear of the damper hub. Use Blue Loctite 242 on all bolts and torque any 3/8" bolts to 28-30 ft/lbs and 5/16" bolts to 16-18 ft/lbs evenly. NOTE: Chrysler (6) bolt dampers are not furnished with pulley bolts.
- Press the Damper & Hub assembly onto the crankshaft using the proper install tool. (Refer to your damper Installer/Removal tool instructions to properly press damper onto the crank.) If you wish to install the hub onto the crankshaft first, use the proper pulley installer. Because of clearance issues in some vehicles, and certain design features on some ATI dampers, the hub may need to be installed before the damper body can be affixed to the hub (i.e. some sport compacts and some Cummins diesels).

IMPORTANT: NEW CRANK BOLT(S) SHOULD BE USED FOR ALL INSTALLATIONS

- Install the OEM crank bolt(s) along with the correlating washer(s), or crank bolts(s) and washer(s) and torque to the manufacturer's specifications unless part number specific instructions specify otherwise (i.e. aftermarket LS damper bolts).

A SINGLE LONG BOLT SHOULD NOT BE USED TO RETAIN THE DRIVE MANDREL AND THE DAMPER TO THE CRANK AS IT WILL STRETCH WHEN IT GETS HOT

- For front mounted crank pulleys with the 3/8" 12-point, 5/16" Torx, 5/16" 12-point, or button head bolts provided, insert the (3) (4) or (6) bolts through the pulley and into the hub. Make sure the pulley is located on the damper hub ID or on the face register. Use Blue Loctite 242 on all bolts and torque any 3/8" bolts to 28-30 ft/lbs, and 5/16" bolts to 16-18 ft/lbs evenly.

THESE BOLTS MUST BE INSTALLED AND TORQUED EVEN IF NO PULLEYS ARE USED.

Damper Mandrels and Mandrel Bolts

ATI dampers, in all cases, must be retained to the crank with a standard length bolt torqued to the manufacturer's specifications. Long bolts used to retain drive mandrels stretch when they get hot and should not be used. ATI manufactures special hubs for many engines to put the bolt below flush and allow drive mandrels to be located and bolted to the 3 pulley bolt holes. ATI can duplicate your existing long bolt drives to bolt-on mandrel type in one week without plating. Mandrels are drilled and tapped to retain pulleys and dry sump drives. Mandrels, pulleys and accessory drives are available from:

ATI	800-284-3433	Moroso.....	203-453-6571
ARE Dry Sump	916-652-5282	Peterson Fluid Systems	800-926-7867
CV Products	800-448-1223	RaceMate	800-671-1711
Jones Belt Drives.....	610-847-2028		



Installing Super Dampers on Chevy LS Engines

*** ATTENTION: Manual transmission Corvette owners ***

A very small percentage of manual transmission equipped Corvettes had a balance issue from the factory. GM has addressed this issue in the repair manual. They inserted a 1/4" dowel in the appropriate hole in the outer ring of the damper. Each car is different. You **MUST** look at your OEM damper **BEFORE** you remove it and see if it has a weight applied. If so, you must make note of its location in reference to the crank position. Since the LS crankshafts are not keyed, once the damper is removed, there is no point of reference and no chance of reattaching it correctly.

Installing the hub onto the crank

Additional tools you may need: 1/2" 6 or 12 point socket

1. Remove existing damper bolt and damper from engine. If necessary, use ATI Puller/Installer (p/n 918999) with Adapter for LS1/LS7 (p/n 918999SC) or similar damper puller. **Save your old bolt for installation in the last step. (OEM bolts are a 1-time use only bolt - do not reuse as a primary bolt!)**
2. Depending on the year of your engine / vehicle you may notice a thin "friction" washer behind the damper hub in front of the first oil pump gear. This washer should be left in place and will not hurt anything if you are or are not pinning or keying your crankshaft. If your year does not have this washer and you would like to add one, there must be a machined "lip" provision on the back of the hub to do so.

If you are not using a key or pin, you must fill the key slot with some high temp silicone so no oil leaks past the damper bolt washer!

3. This would be the time to consider whether or not you would like to pin the crankshaft as the ATI damper has a keyway in the hub unlike many OEM dampers. If you decide to pin the crankshaft (a must for super charging), you will need to purchase ATI's LS1 Crank Pin Drill Fixture (p/n 918993) and follow the instructions enclosed with the Fixture before proceeding to step 6.
4. If a rear pulley (i.e. 4 rib A/C) is being used, it must be placed on the back of the hub before the hub is pressed on the crank.

Installing an Accessory Pulley

Note! Most LS dampers will include a front or rear pulley for OEM accessory drives. If no front pulley is used and/or you choose not to use a front or rear mounted pulley, you **MUST** still put the additional (3) bolts through the unit for a total of (9) bolts holding the assembly together and to the hub. Some applications require the damper shell or hub to be modified if a rear pulley is not used.

 **Damper damage will occur if you do not use at least nine bolts total!**

Using the GM Factory Bolt

Note! The GM factory bolt is a 1-time use bolt! Directions are for installing a new bolt only, part #951499 for wet sump LS or part #951500 for LS7 / LS9.

1. Use your old bolt to install the damper and torque to 240 ft/lbs, then remove it. This is to seat the damper completely.
2. Install your new bolt and tighten to 37 ft/lbs. We recommend Blue or Red Loctite here if you are doing any high performance driving with this engine.
3. This step is to get a reference on the front of the engine. With the torque wrench hanging at the spot where the 37 ft/lbs was achieved, reference 140° clockwise for another tightening cycle. Put a mark or a piece of tape where you need to tighten.
4. Then go another 140° from the 37 ft/lbs starting point and you are now tight.

If using an aftermarket ARP Bolt for any LS damper, or bolt p/n 951359 (16 mm, 10.9 grade) supplied with Super Damper p/ns 918844, 918845, 918852 and 918855):

1. Apply high temperature RTV to both sides of the washer prior to installation.
2. Use 262 Red Loctite and tighten to 230 ft/lbs.

LS CRANK BOLTS

OEM GM - LS1/2/3/6, L92
& '2014* LT1/ LT4 Wet Sump951499

OEM GM - LS3/7/9
& '2014* LT1/ LT4 Dry Sump.....951500

LS1/2/3/6 and L92 - ARP.....951503

For Dampers with Aluminum Hubs

All dampers with aluminum hubs have a .002" press fit between the crank and the hub. DO NOT ALTER the press fit of the hub in any way! The press fit on the aluminum hub is slightly tighter to compensate for the elasticity of the aluminum.

Inspect your crankshaft and the crank key as described on the first page of the instructions. Also use anti-seize lubricant on the crank snout.

To expand the hub slightly and help it slide onto the crank, place hub in boiling water or coffee pot burner for five (5) minutes. Use gloves to handle the hub after it has been heated. After installing the hub, allow time for it to cool.

For damper bolt installation, refer to Page 2 (Step 8) for non-LS applications or Page 3 (bottom) for LS applications.



IF USING A FRONT COVER TEFLON SEAL, YOU MUST HAVE A "SPEEDY SLEEVE" OR A STEEL HUB.

Removal of your Super Damper

1. Remove at least (3) bolts from the damper on an equal pattern for use with damper installer/removal tool.
2. Refer to Damper Installer/Removal tool instructions to remove damper.

Balance Information

Zero balance units should not be drilled and **should not** be on the crankshaft for balancing. Install the damper at engine assembly. Since the inertia weight in the Super Damper is not bonded, it may not be on center until the engine is started. The damper may show out of balance until the engine reaches 2000 RPM the first time and the inertia weight centers itself.

To Tell When Your Damper Needs New Rubber

Drag Race Engines subject the damper to low total cycles at intermittent intervals. Elastomers in all units under 800 HP inspected will easily meet the ten year requirement. Nitrous and Drag Racing engines in excess of 800 HP that see frequent track use should be inspected and rebuilt annually.

Circle Track Engines subject the damper to greatly increased cycle times for an extended period of time and the damper requires more attention.

Sprint Cup, Nationwide Series and Trucks - Most teams are inspecting rubber after each race or every 2 races (2.5 to 3.75 million cycles). Engines running shorter races can easily go 2.5 million cycles since the damper is not subjected to lengthy, continuous cycles under extreme heat.

Recommended Maintenance Schedules

For street and drag race motors (up to 800 HP) damper should be rebuilt every 10 years

Above 800 HP, Blown or Nitrous racing, damper should be rebuilt annually

Circle Track / Endurance dampers should be rebuilt during each engine rebuild

For 5.5" dampers, rebuild depends on HP

- 400 HP rebuild every 5 years
- 400-600 HP rebuild every 2 to 3 years
- 600+ HP rebuild every year

Should you need to return your Super Damper for any reason -- overhaul, repair, etc. -- please call ATI at 410-298-4343 or 800-284-3433 to receive your RGA # (Returned Goods Authorization).